

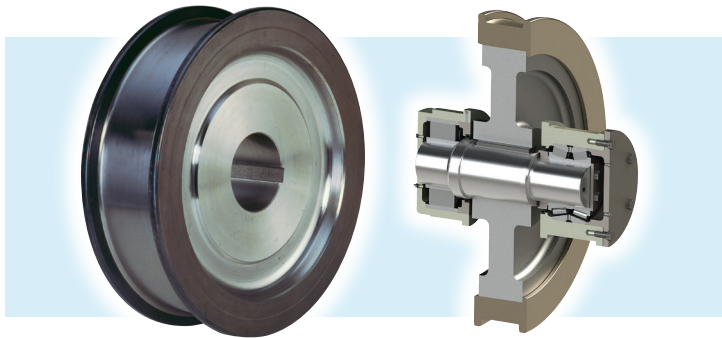

# Xtek®

## Port Crane Wheels

**LESS DOWNTIME    LONGER LIFE    MORE DURABLE    SIGNIFICANT SAVINGS**



### TRACK WHEELS

Since 1909, Xtek has set the standard for crane wheels with its rich history of metallurgy and material selection expertise, delivering products that withstand extreme operating conditions. Our track wheels help customers **maintain efficiency and confidence** in their systems.

With more than a century of experience, we have developed a range of modified forged steel alloys, each designed to excel in the toughest applications. Xtek wheels are built to last with surface hardness and flange properties that set the industry standard.

**Our extended lifespan reduces downtime and replacement costs**, while USA-sourced and manufactured production allows you to keep inventory lean without sacrificing readiness.

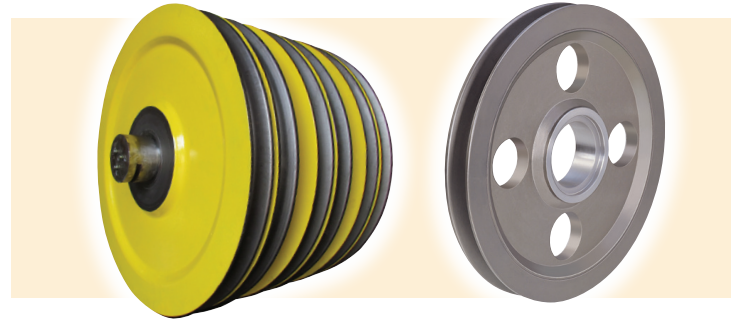
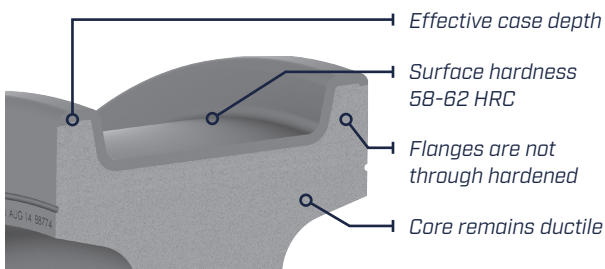

### SHEAVE WHEELS

Xtek's proprietary carburized and hardened TSP sheave wheels consistently outperform competitor's, with customers typically reporting **lifespans over 5 times longer** and **wire rope life that is extended by 3-6 times**—thanks to their deeply hardened and smooth wear surface.

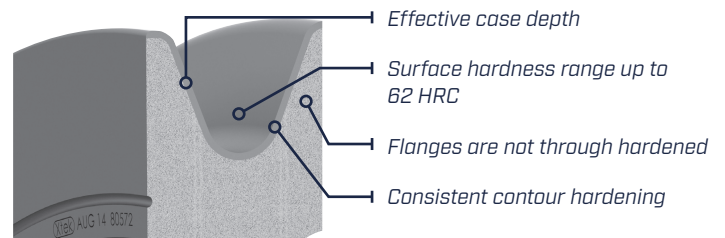

*Advanced Xtek carburized and hardening processes ensure substantially longer life for our wheels, reducing wire rope wear, which results in less downtime and fewer parts replacements. Our customers enjoy healthy cost savings with increased productivity.*

**“We use Xtek wheels and sheaves and our operation sees numerous benefits from their longer service life.”**

**EAST COAST MAINTENANCE MANAGER**

# 2+ YEAR CASE STUDY AT THE PORT OF LOS ANGELES

**Extended lifespan:** Our crane wheels, made from a modified AISI 1055 steel with 60 Rc hardness, have lasted over **2 years**, significantly outlasting the OEM wheels that wore out in just **6-9 months**.

**Reduced downtime:** With a lifespan over **3-4x longer** than OEM wheels, our solution minimizes frequent replacements, reducing maintenance interruptions and keeping ASC cranes operational longer.

**Increased efficiency:** Less downtime means continuous operations, **increased TEU capacity**, and smoother container handling with fewer stoppages.

**Cost savings:** Fewer wheel replacements lead to **lower maintenance costs**, reduced labor, improved safety, and minimal disruption to terminal logistics, translating into long-term financial benefits.

## COMPARE OEM TO XTEK: THE SAVINGS ARE SIGNIFICANT

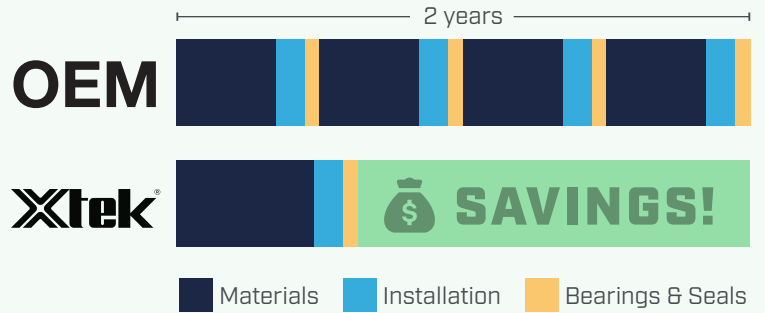

**“In addition to a quality product, Xtek offered technical help that no other competitor would.”**

**WEST COAST VP OF  
ASSET MANAGEMENT**



**513.733.7800**

sales@Xtek.com • xtek.com  
11451 Reading Rd., Cincinnati, OH 45241  
fax: 513.733.7894



9001:2015  
14001:2015

